

A Tutorial on Using Reliability Growth Cause Analysis (RGCA)

Improved reliability has a cause. Just like a failure has a cause, so too is there a cause for improved reliability. You can wait for a failure to happen and then learn from the experience and change your processes to prevent it. That is root cause failure analysis. But it is not proactive behaviour. Such an approach quickly buries you in fire-fighting. It helps you fix a few terrible failures, but not the tens of thousands of defects that are waiting to create the next lot of disasters. Permanent reliability growth requires proactive methodologies that identify all potential problems and stops them from starting. This is what is done in high reliability operations – they never allow defects to begin.

The process maps of your business processes, the workflow diagrams of your operating procedures and the bills of materials for your equipment are the foundation documents for improving equipment reliability. They are used respectively to control the business processes, to control human error and to address limitations in materials of construction and parts’ health practices.

The Reliability Growth Cause Analysis (RGCA) uses team brainstorming to find ways to grow reliability in a business process or equipment part. It looks for what can be done to intentionally reduce stress and remove risk from a situation. A process map is drawn of the process, or work tasks, or for a machine. The map is used to identify every possible way to prevent failure and eliminate defects throughout the life cycle. Box by box, or part number by part number of a bill of materials, every identifiable way to remove and prevent stress, or to improve the working environment, or to eliminate risk to reliability, is identified. Details of the causes of reliability are listed in a spreadsheet, along with the required information. Table 1 shows the information required. Together the team identify the strategies, practices and skills needed in design, manufacturing, procurement, construction, operations, and maintenance to deliver lifetime reliability. A plan is developed to introduce them, including all necessary documents, training and skills development.

Failure Description: _____
Failure Cause: _____
• Frequency of Cause:
• Time to Repair:
• DAFT Cost:
• Causes of Stress/Overload:
• Causes of Fatigue/Degradation:
• Current Risk Matrix Rating:
• Controls to Prevent Cause:
• Est. failures prevented after risk controls in use (/yr):
• New Risk Matrix Rating:
• DAFT Cost savings from higher reliability:

Table 1 – Reliability Growth Cause Analysis Requirements

The RGCA method adopts the same strategy for reliability growth as the world-class leaders in industrial safety use for workplace safety improvement. They proactively improve safety by identifying safety risks and installing appropriate protection and improvements against harm before incidents happen. They don’t let defects that can become accidents even start. RGCA assumes that

failures will happen to equipment parts from defects created in engineering, manufacturing, operations, maintenance, installation and procurement processes unless they are intentionally prevented. It requires recognising what can cause risk in all stages of a parts life-cycle and make necessary improvements to prevent every cause starting. Reliability grows by using the right practices and processes that prevent defects and risk, alongside those that proactively promote health and wellness. RGCA requires you to identify ways that will drive improvement, and not simply prevent failure. The aim is to never allow a process step or part to fail, and requires the team to list all the ways that reliability can be maximised. The level of business risk determines which reliability growth improvements will be used and then drives their rapid introduction.

An example of the methodology is used on the inner race of the bearing shown in Figure 1. The process map of the shaft and bearing arrangement in Figure 2 confirms the configuration is a series arrangement. Hence it is an at-risk assembly, and the entire system, the electric motor, would breakdown should it fail.

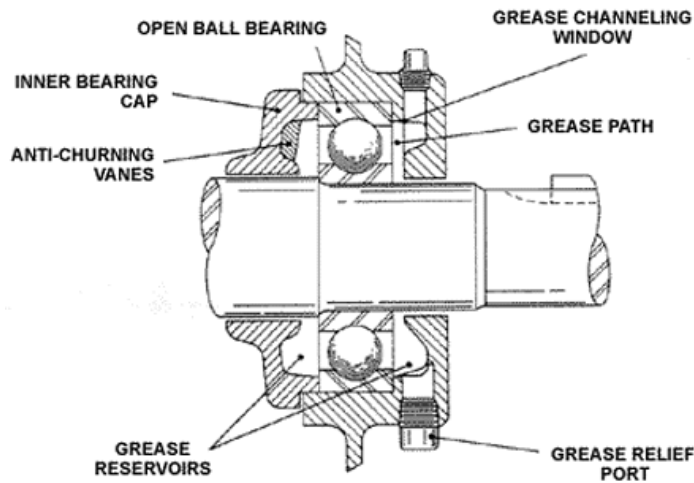

Figure 1 - AC Electric Motor Bearing Arrangement

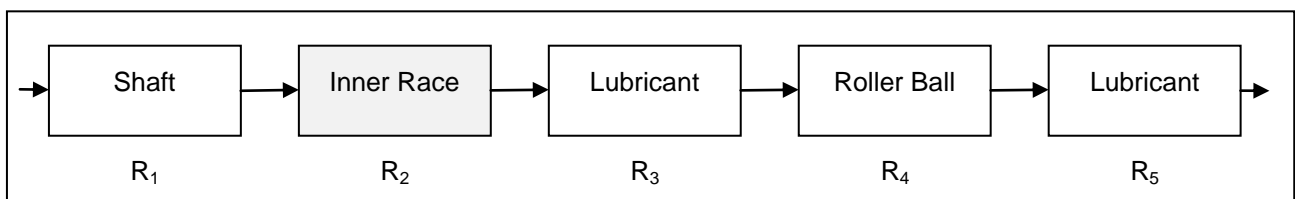

Figure 2 – Process Flow Map for Roller Bearing on Shaft

First, a list of known and possible inner race failures is written by the analysis team. Known inner race failures include a cracked race, a scoured and scratched race, a brinelled and indented race, a loose fitting race, a race suffering electrically arcing, and so on until the team has exhausted all failure modes known to its members. Possible failure modes are then imagined, and include a cracked race intentionally installed and a cracked race unknowingly installed. The next step is to ask of each failure mode how its cause can arise - how can the inner race be cracked? A cracked race can occur from excessive interference fit on the shaft, or a huge impact load, or the shaft is oval and the round race is forced out-of-shape, or a solid piece of material is trapped between the race and shaft during the fitting, or the shaft is heavily burred and the race is forced over the burr and is damaged in the installation process.

For the first cause noted of a cracked inner race, excessive interference fit, the team asks – “How is excessive shaft interference prevented?” This problem is one of incorrect tolerances between race and shaft. It is usually a manufacturing error of the shaft or the race. The team is now required to develop proactive measures to ensure a race is never fitted to an incorrectly made shaft, or an incorrectly made race is never fitted to a good shaft. One prevention is to micrometer the shaft and the race and check the fit matches the bearing manufacturer’s requirements for the model of bearing. Additional prevention is to confirm the model of bearing is correct for the service duty and operating temperatures. These checks become a procedural requirement written into the ACE 3T procedure for the job. But the team is charged with finding all cause of reliability, and much more can be done earlier in the life cycle to prevent this failure. These additional early life cycle preventive measures are listed in Table 2.

The team then continues with the next cause of how an inner race can be cracked – heavy impact – and develops preventive actions (heavy impacts can occur when a race is fitted to a shaft with hammer blows or overloaded in a press, or a loose race on the shaft rattles from side to side, or a badly aligned shaft causes the race to be cyclically loaded, or it suffers a huge start-up overload). The process continues for a shaft that is oval, for a solid piece of material trapped between race and shaft during the fitting, for a heavily burred shaft, and so on. With each preventive measure put into place and made standard practice through using ACE 3T procedures and workforce training, each part’s reliability grows.

Worked RGCA Example 1

Failure Description: Cracked inner roller bearing race		
	Failure Cause 1: Excessive interference fit	Failure Cause 2: Impact to race
Frequency of Cause:	Early Life – 1 per year	Random – 3 per year
Time to Repair:	5 hours	10 hours
DAFT Cost:	\$20,000	\$25,000
Causes of Stress/Overload:	<ul style="list-style-type: none"> • Large shaft • Small bearing race bore 	<ul style="list-style-type: none"> • Abuse when fitting • Start-up with equipment fully loaded
Causes of Fatigue/Degradation:	Not applicable	<ul style="list-style-type: none"> • Misaligned shafts • Loose race moving on shaft
Current Risk Matrix Rating:	Medium	Medium
Controls to Prevent Cause:	<ul style="list-style-type: none"> • Update all bearing fitting procedures to measure shaft and bore and confirm correct interference fit at operating temperature and train people annually • Update all machine procurement contracts include quality check of shaft diameters before acceptance of machine for delivery • Update all bearing procurement contracts to include random inspections of tolerances • Update all design and drawing standards to include proof-check of shaft measurements and tolerances 	<ul style="list-style-type: none"> • Update all bearing fitting procedures to include using only approved tools and equipment and train people annually. Purchase necessary equipment, schedule necessary maintenance for equipment • Change operating procedures to remove load from equipment prior restart and train people annually (Alternative: Soft start with ramp-up control if capital available) • Align shafts to procedure and train people annually • Update bearing fitting procedures to measure shaft and bore and

	on drawings suit operating conditions once bearing is selected	confirm correct interference fit at operating temperature and train people annually
Est. failures prevented after risk controls in use (/yr):	All future failures	80% of future failures
New Risk Matrix Rating:	Low	Low
DAFT Cost savings from higher reliability:	\$20,000 per year	\$60,000 per year

Table 2 – Example of Reliability Growth Cause Analysis on Inner Race of a Roller Bearing

Every RGCA performed applies to every similar situation, and the learning from one analysis is transferred to every other similar situation by updating all other applicable procedures. In this way RGCA applies Series Reliability Property 3, and rapidly improves every other like circumstance.

Worked RGCA Example 2

This example uses the Bill of Materials and Parts List of a diesel engine driving a fire pump in a gasoline fuel storage terminal to perform a RGCA on the working parts of the engine. The engine is a vital element of the fire fighting service should the terminal have a blaze. There is a back-up electric pump also installed that will first come on if a fire happens. However if the electrical power supply fails the diesel pump is started-up and used to fight the fire.

First always develop a process map of the equipment parts’ in use when the machine is in operation so you can recognise each item in the ‘chain of parts’ that will cause the machine to fail. Where you see a series arrangement you know it is a high risk area for failure and you can then identify ways to increase the lifetime reliability of the working parts in series within the machine.

Reliability Growth Cause Analysis is all about failure prevention and defect elimination. The aim is always not to allow a cause of failure to develop. We seek to understand how parts will fail in service and to then install the right methods and practices throughout the equipment life cycle that will stop defect creation so dangers are not present in future to cause an operational failure.

Every part of the life cycle is considered when looking where to proactively prevent defects arising. From design and capital equipment selection, through to Boardroom decisions and down to the operating procedures and maintenance practices, RGCA requires us to ask how best to protect against failure causing defects and latent situations arising that can become future plant and machinery breakdowns. You use RGCA to recognise where your operating risks arise and what you need to do to practically prevent them from developing.

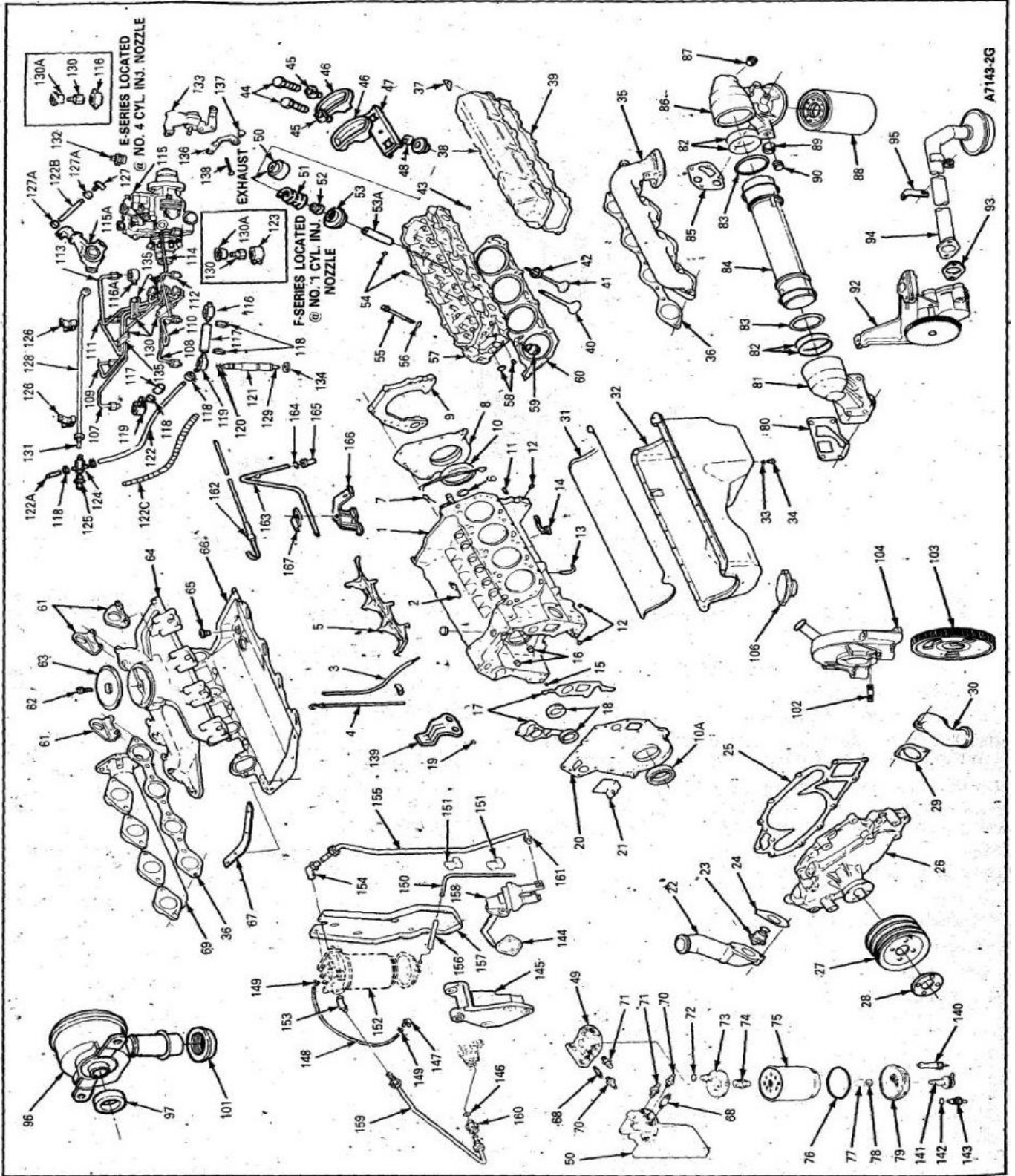

Figure 3 Engine Parts Exploded Drawing

REF. NO.	BASIC PART NO.	DESCRIPTION	REF. NO.	BASIC PART NO.	DESCRIPTION	REF. NO.	BASIC PART NO.	DESCRIPTION	REF. NO.	BASIC PART NO.	DESCRIPTION
1	6009H	Cylinder Block Assy.	45	—	Post. Valve Lever	89	—	Plug, 1/2 Inch	132	9E999	Temperature Switch
2	60329A	Guide, Tappet	46	—	Lever, Valve	90	—	Plug, 1/2 Inch	133	12B526	Bracket and Solenoid-Fast Idle
3	6754	Tube Assembly, Oil Level Gauge (F-Series)	47	—	Retainer, Valve Lever Post	92	6600	Oil Pump Assy.	134	—	Gasket Nozzle (6)
4	6750	Oil Level Gauge (F-Series)	48	—	Lock, Valve Spring Retainer	93	6626	Gasket, Oil Pick-Up	135	9N653	Clamp
5	6C330A	Retainer, Tappet Guide	49	6514A	Retainer, Valve Spring (36)	94	6622	Pick-Up Tube	136	9F541	Kickdown Lever (Auto. Trans.)
6	6026A	Plug, Engine (1-1/2" O.D.)	50	—	Shield, Oil (Exhaust)	95	6A661	Bracket, Oil Pick-Up	137	9D827	Screw, Kickdown Lever
7	6D063A	Gasket, Rear Cover	51	6513B	Spring, Valve, with Damper (16)	96	6A665	CDR Valve	138	9F539	Adjusting Screw (Kickdown Lever)
8	6L080A	Cover Assembly, Engine, Rear	52	6571A	Seal, Valve Stem-Intake (8)	97	6A682	Seal Ring, CDR Valve	139	6786	Bracket, Oil Level Tube Support (F-Series)
9	6A389A	Adapter, Flywheel to Transmission	53	6K533A	Rotator, Assembly Valve (16)	100	6758	Crankcase Vent. Tube	140	—	Vent/Valve Assembly
10	6701A	Rear Oil Seal, Crankshaft	54	—	Guide, Valve (Service)	101	6769	Grommet, Valley Cover	141	—	Manual Drain Valve
10A	—	Front Oil Seal	55	6065A	Plug, 1/2 inch NPTF (4)	102	9F733	Mounting Stud, Injection Pump	142	—	Water Sensor O-Ring
11	6B041B	Dowel Pin, Fly Wheel Adapter	56	6L015A	Washer, Cylinder Head Bolt (34)	103	9A546	Drive Gear, Injection Pump	143	—	Water Sensor Probe
12	87614S	Pipe Plug, 1/8 NPTF	57	6049A	Cylinder Head Assembly (2)	104	9C516	Adapter Housing, Injection Pump	144	—	Fuel Pump Supply Gasket
13	6C327A	Riston Cooling Jet	58	6026B	Plug, 1/4 Inch	106	6766	Cap, Oil Filler	145	—	Alternator Bracket
14	6A051A	Heater Assembly, Block	59	6057A	Insert, Combustion Chamber (8)	107	9A555H	Pipe w/Nuts Pump to Cyl. 8	146	—	Sealing O-Ring
15	6B041A	Dowel Pin, Front Cover Plate	60	6051B	Gasket, Cylinder Head (2)	108	9A555G	Pipe w/Nuts Pump to Cyl. 7	147	—	Fuel Return Tee (At Nozzle)
16	6026E	Cup Plug	61	—	Eye, Lifting (3)	110	9A555E	Pipe w/Nuts Pump to Cyl. 5	148	—	Hose, 3/16" ID x 10" Long
17	6020A	Gasket, Front Cover Plate	62	9C629A	Insert, Bolt Thread-Air Cleaner, Stud	111	9A555D	Pipe w/Nuts Pump to Cyl. 4	149	—	Hose Clip
18	6A251A	Bearing Kit, Camshaft	63	9F460A	Screen, Intake Manifold	112	9A555C	Pipe w/Nuts Pump to Cyl. 3	150	—	Water Drain Tube
19	6A628A	Bell, Oil Indicator Hole 11/32"	64	9424B	Manifold, Intake	113	9A555B	Pipe w/Nuts Pump to Cyl. 2	151	—	Drain Tube Clamp (2)
20	6B070A	Plate, Front Cover	65	9A450A	Drain Plug, Valley Pan	114	9A555A	Pipe w/Nuts Pump to Cyl. 1	152	—	Fuel Filter/Water Separator Element
21	—	Indicator, Timing (Part of Front Cover)	66	9439B	Gasket and Valley Pan Strap, Valley Pan	115	9A543	Injection Pump	153	—	Elbow
22	8592G	Connection, Water Outlet	67	95470A	Fuel Priming Valve and Cap	115A	—	Valve, Vacuum Modulator (Auto. Trans.)	154	—	Elbow, Fuel Supply Pump to Filler Header
23	8575	Thermostat	68	9430A	Manifold, Exhaust, Right	116	—	Fuel Return Tee	155	—	Fuel Pump to Fuel Header Tube (With Two Nuts and Two Sleeves)
24	8255A	Gasket, Water Outlet	69	9430A	Continuous Vent with Check Valve	116A	—	Elbow, Fuel Return (F-Series)	156	—	Hose, 3/16" x 2-5/16" Long
25	8507A	Gasket, Water Pump	70	—	Vacuum Switch (Fuel Filter Element Replacement Indicator)	117	—	Hose	157	—	Fuel Filter Header Mounting Bracket
26	8501D	Water Pump	71	—	Fuel Heater O-Ring	118	9B255	Clip	158	—	Fuel Supply Pump
27	8509D	Pulley, Water Pump	72	—	Fuel Heater	119	9A564	Fuel Return Tee	159	—	Filter to Injection Pump Tube (With Two Nuts and Two Sleeves)
28	8546A	Spacer, Fan	73	—	Threaded Insert	120	87032-592	O-Rings	160	—	Connector Fitting
29	8255A	Gasket, Water Inlet	74	—	Fuel Filter Element	121	9E527	Injection Nozzle Holder	161	—	Inverted Flare Tube Nut
30	8592D	Connection, Water Inlet	75	—	Drain Bowl O-Ring	122	—	Fuel Return Hose	162	—	Oil Level Gauge — E-Series
31	D6AZ-19662-A	RTV Sealant	76	—	Drain Valve Stem Cap	122A	—	Hose	163	—	Tube Assembly, Oil Level Gauge — E-Series
32	6675C	Oil Pan	77	—	Drain Valve Seal	123	—	Fuel Return Tee (E-Series)	164	—	O-Ring, Oil Level Gauge — E-Series
33	6734A	Gasket, Oil Pan Drain	78	—	Water Separator Drain Bowl	124	9F734	Fuel Return Junction Fitting	165	—	Oil Level Gauge Tube, Lower — E-Series
34	6730A	Plug, Oil Pan Drain	79	—	Gasket, Oil Cooler, Front Header	125	—	Nipple, Fuel Return	166	—	Bracket, Oil Level Gauge Tube — E-Series
35	9431B	Manifold, Exhaust, Left	80	6A636A	Header, Oil Cooler, Front	126	9N659	Clamp	167	—	Retainer, Oil Level Gauge Tube — E-Series
36	9448A	Gasket Exhaust Manifold	81	—	O-Ring, Oil Cooler (2)	127	9F736	Elbow	—	—	—
37	6A532A	Washer, Valve Cover	82	6K649A	O-Ring, Oil Cooler (2)	127A	—	Clip	—	—	—
38	6592C	Valve Cover	83	6C610A	O-Ring, Oil Cooler (2)	128	9D308	Tube	—	—	—
39	6584A	Gasket, Valve Cover	84	6A642A	Cooler, Oil	129	—	Nozzle Tip	—	—	—
40	6507D	Valve, Intake (8)	85	6A636B	Gasket, Oil Cooler, Rear Header	130	—	Sensor, Fuel Line Pressure	—	—	—
41	6505	Valve, Exhaust	86	6881B	Header, Oil Cooler, Rear	130A	—	Cover	—	—	—
42	6057B	Insert, Exhaust Valve Seat	87	6K962A	Plug, 1/4-inch	131	9C387	Sleeve Seal, Fuel Return (2)	—	—	—
43	6026F	Plug, Ball Type 13/32" (8)	88	6731A	Oil Filter	—	—	—	—	—	—
44	—	Bolt, Valve Lever and Washer	—	—	—	—	—	—	—	—	—

Figure 4 Engine Parts List

WORKED EXAMPLE 2

(See at end of the example the Risk Matrix used in this analysis)

Process Map of Selected Parts Operation and Use

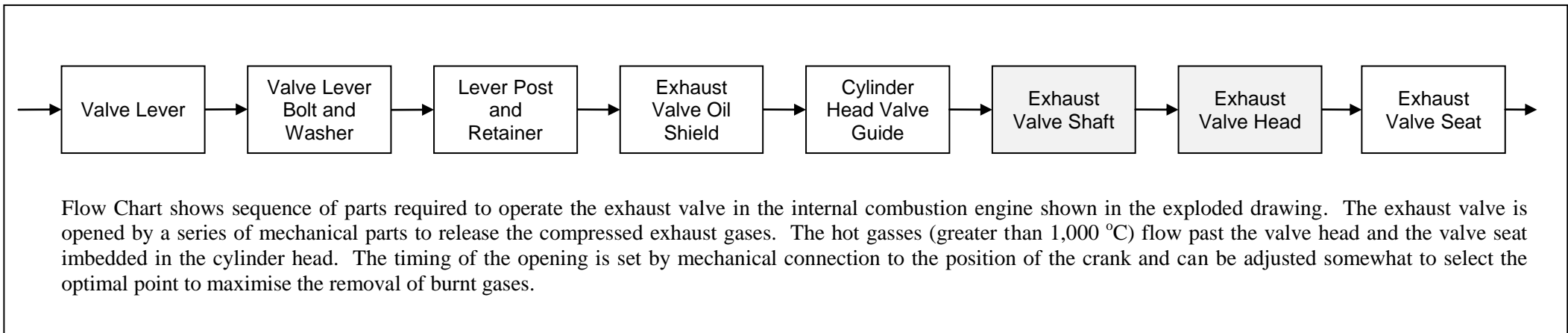

Step / Item / Part Description:	Item 41 - Valve, Exhaust
Procedure / Drawing No and Description:	Bill of Materials and Exploded Parts Drawing for Internal Combustion Engine
Process Description:	Fuel Terminal Fire Water Supply Pump Drive Motor – required operating life is 50 years(potential to be 100 years)
Part Number:	6505
Effect of Step/Item/Part failure?	Engine cannot operate at full capacity since exhaust valve damage prevents compression. If valve failure occurs during fire fighting duty only the stand-by electric fire pump is available for back-up duty.
Failure of Step/Item/Part causes system failure (Y/N)?	Yes, if not repaired at onset of valve damage engine block head and cylinder block piston can be destroyed
Total DAFT Cost Savings Possible (\$/yr):	A complete strip down and rebuild of the engine costs \$25,000 and 1 month downtime. Over a 50 year life this produces an annualised cost of \$500/year. Above the financial cost, the company’s reputation will become poor with the Regulators should the fire pump drive engine fail.
Risks and Controls	
Failure Stress Cause 1:	Exhaust valves’ seat burnt from normal usage

Freq of Cause 1:	The engine has a total of about 100 hours of operation per year. The motor is run for two hours each week on test and to prove the fire water piping circuit does not leak. Each valve could fail after about 4,000 hours of operation (around 40 years), though unlikely to fail before 3,000 hours in service (about 30 years).
Time to Repair 1:	Up to 1 month
DAFT Cost:	\$25,000 once in 50 year operating life with motor sent off-site for urgent repair (An annualised cost of \$500)
Causes of Stress/Overload:	Not applicable
Causes of Fatigue/Degradation:	Exhausts valves are expected to degrade with usage
Current Risk Matrix Rating:	This motor has a service life of 50 year as a fire pump prime mover in a tank terminal. Should it fail the Regulators will scrutinise the operation and become concerned that the company has poor maintenance practices. Likelihood 3 + Consequence 3 = M
Controls to Prevent Cause:	Introduce planned schedule replacement of all exhaust valves, seats and valve guides at 3,000 hours or 25 years service, whichever is first
Est failures prevented after risk controls in use (/yr):	No failures are expected due to this mode of failure if exhaust vales are replaced every 25 years
New Risk Matrix Rating:	Likelihood 1 + Consequence 3 = L/M
DAFT Cost savings with higher reliability:	The planned refurbishment requires new exhaust valves and reseating. It is a two day done on-site job. Cost \$5,000 every 25 years.
Failure Stress Cause 2:	Exhaust valve seat burnt from a valve timing error
Freq of Cause 2:	The engine is tuned once annually, or about every 100 hours of operation
Time to Repair 2:	Up to 1 month
DAFT Cost:	\$25,000 once in 50 years motor sent off-site for urgent repair (An annualised cost of \$500)
Causes of Stress/Overload:	Localised high temperature at valve head edges and valve seat as exhaust gas flows past valve and seat due to valve closing late or opening early
Causes of Fatigue/Degradation:	Not applicable
Current Risk Matrix Rating:	The opportunity for a timing error arises annually and will not be corrected for twelve months, provided the error is then detected. In a 50 year operating life there will be 50 opportunities to mistakenly set valve timing. With 100 hours of annual service accumulated at a rate of two hours per week there is little time for the valve/seat to be burnt by one error. The valve is most likely to fail if the valve timing is not rectified for some years. Likelihood 3 + Consequence 3 = M
Controls to Prevent Cause 2:	Introduce ACE 3T procedures to control tasks and to ensure a record of all valve timing adjustments is made and can be used to compare future settings.

Est failures prevented after risk controls in use (/yr):	No failures are expected due to this mode of failure after ACE 3T procedures and recording is introduced
New Risk Matrix Rating:	Likelihood 1 + Consequence 3 = L/M
DAFT Cost savings with higher reliability:	No costs are expected in future from this failure mode when mitigation is performed
Failure Stress Cause 3:	Valve train and associated parts are wrongly installed and components come loose or break and valve falls into cylinder
Freq of Cause 3:	This failure is only expected after a rebuild of the motor or a cylinder head is refurbished or replaced. The opportunity for this failure arises whenever other failure causes require the engine or cylinder heads to be removed. Errors in rebuilding such a complicated piece of equipment should be expected. It is estimated that once every twenty years a rebuild will arise, which is twice during the motor's operating life, and one of them will go wrong.
Time to Repair 3:	Up to 1 month
DAFT Cost:	\$25,000 once in 50 year operating life with motor sent off-site for urgent repair (An annualised cost of \$500)
Causes of Fatigue/Degradation:	Human error or faulty parts
Current Risk Matrix Rating:	Likelihood 3 + Consequence 3 = M
Controls to Prevent Cause 3:	Introduce ACE 3T procedures to control engine rebuild and overhaul tasks. If work is done by subcontractor or repair shop, ensure compliance to ACE 3T precision quality standards and instigate tests and observation during rebuild to confirm compliance to quality requirements
Est failures prevented after risk controls in use (/yr):	No failures are expected due to this mode of failure after ACE 3T procedures and recording is introduced
New Risk Matrix Rating:	Likelihood 1 + Consequence 3 = L/M
DAFT Cost savings with higher reliability:	No costs are expected in future from this failure mode when mitigation is performed
DAFT Cost Savings (\$/yr):	Total annualised savings of \$1,500 is expected from the above mitigations

Summary Table of Reliability Growth Cause Analysis Plan

Failure Description: Failure of Exhaust Gas Valve in Fire Pump Drive Motor			
	Failure Stress Cause 1: Exhaust valves' seat burnt from normal usage	Failure Stress Cause 2: Exhaust valve seat burnt from a valve timing error	Failure Stress Cause 3: Valve train parts are wrongly installed and components come loose
Frequency of Cause:	Wear-out – 1 per 50 years	Random – 1 per 50 years	Early life failure – 1 per 50 years
Time to Repair:	Up to 1 month	Up to 1 month	Up to 1 month
DAFT Cost:	\$25,000	\$25,000	\$25,000
Causes of Stress/Overload:	Not applicable	Exhaust gasses burn valve	Parts come loose and fail to operate properly or break
Causes of Fatigue/Degradation:	Gradual degradation from use	Not applicable	Not Applicable
Current Risk Matrix Rating:	Medium	Medium	Medium
Controls to Prevent Cause:	Introduce planned schedule replacement of all exhaust valves, seats and valve guides at 3,000 hours or 25 years service	Introduce ACE 3T procedures to control tasks and to ensure a record of all valve timing adjustments is made and can be used to compare future settings.	Introduce ACE 3T procedures to control engine rebuild and overhaul tasks.
Est. failures prevented after risk controls in use (/yr):	All future failures prevented	All future failures prevented	All future failures prevented
New Risk Matrix Rating:	Low/Medium	Low/Medium	Low/Medium
DAFT Cost savings from higher reliability:	\$500 per year	\$500 per year	\$500 per year

Risk Assessment Matrix

E – Extreme risk – detailed action plan required
H – High risk – needs senior management attention
M – Medium risk – specify management responsibility
L- Low risk – manage by routine procedures

Extreme or High risk must be reported to Senior Management and require detailed treatment plans to reduce the risk to **Low** or **Medium**

				Consequence					
				People	Injuries or ailments not requiring medical treatment.	Minor injury or First Aid Treatment Case.	Serious injury causing hospitalisation or multiple medical treatment cases.	Life threatening injury or multiple serious injuries causing hospitalisation.	Death or multiple life threatening injuries.
				Reputation	Internal Review	Scrutiny required by internal committees or internal audit to prevent escalation.	Scrutiny required by clients or third parties etc.	Intense public, political and media scrutiny. E.g. front page headlines, TV, etc.	Legal action or Commission of inquiry or adverse national media.
				Business Process & Systems	Minor errors in systems or processes requiring corrective action, or minor delay without impact on overall schedule.	Policy procedural rule occasionally not met or services do not fully meet needs.	One or more key accountability requirements not met. Inconvenient but not client welfare threatening.	Strategies not consistent with business objectives. Trends show service is degraded.	Critical system failure, bad policy advice or ongoing non-compliance. Business severely affected.
				Financial	<\$200>	<\$2,000>	<\$20,000>	<\$200,000>	<\$2,000,000>
					Insignificant	Minor	Moderate	Major	Catastrophic
					1	2	3	4	5
Likelihood	>1 in 10	Is expected to occur in most circumstances	5	Almost Certain	M	H	H	E	E
	1 in 10 - 100	Will probably occur	4	Likely	M	M	H	H	E
	1 in 100 – 1,000	Might occur at some time in the future	3	Possible	L	M	M	H	E
	1 in 1,000 – 10,000	Could occur but doubtful	2	Unlikely	L	M	M	H	H
	1 in 10,000 – 100,000	May occur but only in exceptional circumstances	1	Rare	L	L	M	M	H

Adapted from Australian Risk Management AS/NZS 4360 - 2004

The Latest Developments in RGCA

One further improvement in the Reliability Growth Cause Analysis technique uses a Physics of Failure (PoF) approach with every part. Once at-risk parts are identified you ask what type and range of stresses will cause each part to fail and where will those stresses arise. The operational stresses a part suffers, and the environmentally induced stresses from being in service, are identified using the guide words listed in the table below.

Once the range and type of stresses causing failure are known we build-in protection during every stage of the life cycle to proactively prevent the situations arising where those stresses could be initiated. This refinement of the RGCA methodology lets you build into your business processes the proper actions and activities right across the life cycle that deliver lasting low operational risk to your equipment parts. The Physics of Failure based RGCA helps you to discover exactly what to do to produce the outstanding reliability you want in your operation, and equally importantly, it also identifies how well you need to do those activities so high reliability is guaranteed.

We apply this method when you ask us in as consultants to identify and create the right reliability improvement strategy you need to reach world class heights of operational performance.

Physics of Failure Factors

Operational Stresses (Horizontal, Vertical, Axial)	Environmental Conditions	Life Cycle Situations
Compressive load	Electrical discharge	Feasibility
Tensile load	Thermal high	Final Design
Shear load	Thermal low	Project Management
Cyclic load	Corrosion	Installation
Shock load	Erosion	Manufacture
Hydraulic shock	Electrostatic	Assembly
Vibration shock	Density gradient	Operation
Power dissipation	Thermal gradient	Maintenance
Pressure	Radiation	Overhaul / rebuild
Voltage	Electromagnetic	Transport
Current	Diffusion	Storage
Frequency	Humidity	
Under-loaded	Contaminant ingress	
Detach-debond-delaminate	Moisture ingress	
Interference fit tight	Chemical reaction	
Interference fit loose	Vibration	
Physical deformation	Misalignment	
Pressure hammer	Lubrication degradation	
Shrinkage	Oxidisation	
	Dissimilar materials	
	Hygro-mechanical (Moisture absorption)	
	Rate of change	

My best regards to you,

Mike Sondalini
www.lifetime-reliability.com